



# EAGLE CORR PE™ \*

MEETS AASHTO & ASTM SPECIFICATIONS

INSTALLATION GUIDE

*\* Also applicable to Eagle Green PE.*





# EAGLE CORR PE™

## CONTENTS

1.0	RECEIVING AND HANDLING PIPE SHIPMENTS . . . . .	8
1.1	INSPECTION . . . . .	8
1.2	UNLOADING . . . . .	9
1.3	STOCKPILES . . . . .	11
1.4	GASKET CARE . . . . .	12
1.5	LOADING TRANSFER TRUCKS . . . . .	12
1.6	DISTRIBUTING ALONG THE TRENCH . . . . .	13
2.0	TRENCH CONSTRUCTION . . . . .	14
2.1	WORKING AHEAD OF THE PIPE LAYING CREW . . . . .	14
2.2	CURVES IN THE TRENCH . . . . .	15
2.3	TRENCH WIDTHS . . . . .	15
2.4	TRENCH DEPTHS . . . . .	16
2.5	PREPARATION OF TRENCH BOTTOM . . . . .	16
2.6	TRENCH SAFETY, TRENCH BOXES AND SHEETING . . . . .	17
3.0	PIPELINE CONSTRUCTION . . . . .	19
3.1	INSPECTION . . . . .	19
3.2	LOWERING PIPE AND ACCESSORIES INTO TRENCH . . . . .	19
3.3	ASSEMBLY OF EAGLE CORR PE™ . . . . .	19
3.3.1	LUBRICANT REQUIREMENTS . . . . .	28
3.4	CATCH BASIN AND MANHOLE STRUCTURES . . . . .	29
3.4.1	TRANSITIONS TO MANHOLES, CATCH BASINS AND OTHER STRUCTURES . . . . .	30

3.4.2	FOUR CONNECTIONS TO MANHOLES, CATCH BASINS AND OTHER STRUCTURES . . . . .	31
4.0	PIPE EMBEDMENT . . . . .	35
4.1	PREPARATION OF THE TRENCH BOTTOM . . . . .	35
4.2	TRENCH EXCAVATION . . . . .	36
4.3	PIPE LAYING . . . . .	37
4.4	FOUNDATION . . . . .	37
4.5	BEDDING . . . . .	37
4.6	INITIAL BACKFILL . . . . .	38
4.7	HAUNCHING . . . . .	43
4.8	EMBEDMENT MATERIALS . . . . .	44
4.8.1	CLASS IA MATERIALS . . . . .	45
4.8.2	CLASS IB MATERIALS . . . . .	45
4.8.3	CLASS II MATERIALS . . . . .	46
4.8.4	CLASS III MATERIALS . . . . .	46
4.8.5	CLASS IV-A MATERIALS . . . . .	46
4.9	FINAL BACKFILL . . . . .	46
4.10	COMPACTION METHODS AND EQUIPMENT . . . . .	48
4.10.1	HAND COMPACTION IN HAUNCH AREA . . . . .	48
4.10.2	MECHANICAL TAMPERS . . . . .	49
4.10.3	WATER-JETTING . . . . .	49
4.10.4	COMPACTION EQUIPMENT SELECTION . . . . .	49
4.11	MIGRATION . . . . .	50
4.12	PARALLEL PIPE INSTALLATION . . . . .	50
5.0	MINIMUM AND MAXIMUM BURIAL DEPTH RECOMMENDATIONS . . . . .	51
5.1	BURIAL DEPTHS . . . . .	51
5.1.1	MINIMUM COVER . . . . .	51

5.1.2 MAXIMUM COVER . . . . . 52

5.2 BURIAL DEPTH RECOMMENDATIONS . . . . . 54

5.3 MAXIMUM COVER HEIGHT ANALYSIS . . . . . 54

5.4 PIPE PROPERTIES . . . . . 55

5.5 CONSTRUCTION AND PAVING EQUIPMENT LOADS . . . . . 56

5.6 SPECIAL CONDITIONS AND CONSIDERATIONS . . . . . 57

    5.6.1 FROZEN BACKFILL . . . . . 57

    5.6.2 VERTICAL INSTALLATION OR RISERS . . . . . 57

    5.6.3 FLOTATION PREVENTION . . . . . 60

    5.6.4 GROUND WATER CONTROL . . . . . 61

    5.6.5 BACKFILLING AND COMPACTING FOR PIPE ON SLOPES . . . . . 61

6.0 PIPE TESTING AND REPAIR . . . . . 61

6.1 DEFLECTION . . . . . 62

6.2 PIPE DEFLECTION TESTING . . . . . 63

6.3 PIPE JOINT LEAKAGE TESTING . . . . . 64

6.4 REPAIR METHODS FOR PIPE . . . . . 64

    6.4.1 SOIL TIGHT REPAIR METHODS . . . . . 64

    6.4.2 WATERTIGHT REPAIR METHODS . . . . . 66

THE PHYSICAL (OR CHEMICAL) PROPERTIES OF EAGLE CORR PE™ STORM DRAIN PIPE PRESENTED IN THIS BOOKLET REPRESENT TYPICAL AVERAGE VALUES OBTAINED IN ACCORDANCE WITH ACCEPTED TEST METHODS AND ARE SUBJECT TO NORMAL MANUFACTURING VARIATIONS. THEY ARE SUPPLIED AS A TECHNICAL SERVICE AND ARE SUBJECT TO CHANGE WITHOUT NOTICE. CHECK WITH JM EAGLE™ PRODUCT ASSURANCE TO ENSURE CURRENT INFORMATION.

## HOW THIS GUIDE CAN HELP YOU

This booklet was written especially for the installer and those who direct the actual handling and installation of Eagle Corr PE™ storm drain pipe. This guide should be used in conjunction with the following applicable industry accepted installation and testing practices. This document should not be considered a full guide or manual in lieu of the following industry practices:

1. AASHTO LRFD Bridge Construction Specification Section 30 –05 (or later)
2. ASTM F449-02 (or later) “Practice for Subsurface Installation of Corrugated Polyethylene Pipe for Agricultural Drainage or Water Table Control.”
3. ASTM F1417-05 (or later) “Installation Acceptance of Plastic Gravity Sewer Lines Using Low-Pressure Air.”
4. ASTM F1668-96 (2002) (or later) “Construction of Buried Plastic Pipe.”
5. ASTM D2321-05 (or later) “Underground Installation of Thermoplastic Pipe for Sewers and Other Gravity-Flow Applications.”
6. ASTM F2487–“Standard Practice for Infiltration and Exfiltration Acceptance Testing of Installed Corrugated High Density Polyethylene Pipelines.”

This guide is meant as an explanatory supplement to the materials above on how to install Eagle Corr PE™ storm drain pipe under normal conditions so as to comply with JM Eagle™ Installation Guide. Any discrepancies between the above standards and the written information contained herein should be brought to the attention of JM Eagle™ Product Assurance immediately for resolution by JM Eagle™ prior to any actions by either contractor, engineer, or municipality.

This guide is not intended to supply design information nor to assume the responsibility of the engineer (or other customer representative) in establishing procedures best suited to individual job conditions so as to attain satisfactory performance.

Engineers, superintendents, contractors, foremen, and laying crews will find much to guide them in the following specifications. This booklet will also be of help in determining pipe needs when ordering.

## Pipe Design

The corrugated HDPE pipe design evolved over the last 40 years from primarily an agricultural drainage product to a dominant product in the entire drainage market. This 40-year evolution has brought about many changes in pipe design and materials. JM Eagle's Eagle Corr PE™ is the culmination of this evolution. Some of the terms used in this installation manual are defined in [Figure 1](#) below.

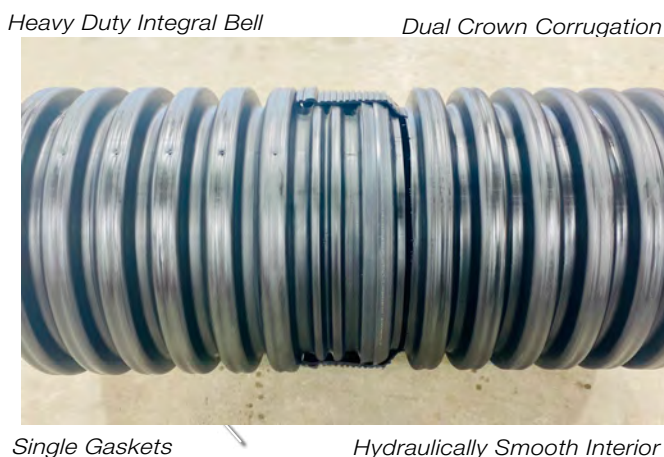

**Figure 1**

Some of these innovations, such as the heavy duty integral bell, are a result of innovations in manufacturing technology which was necessitated by a need to have more robust bells for watertight applications—an evolution others are attempting by wrapping bands around the bell of the pipe and other types of reinforcements. Other innovations, such as the inline bell and spigot, reduce the amount of skill necessary for the contractor and ensure consistent invert grade. These and many more innovations in this pipe design are highlighted in the installation instructions to follow.

## WARRANTY

JM Eagle™ warrants that its standard polyvinyl chloride (PVC), polyethylene (PE), conduit/plumbing/solvent weld and Acrylonitrile-Butadiene-Styrene (ABS) pipe products (“Products”) are manufactured in accordance with applicable industry specifications referenced on the Product and are free from defects in workmanship and materials. Every claim under this warranty shall be void unless in writing and received by JM Eagle™ within 30 days of the date the defect was discovered, and within one year of the date of shipment from the JM Eagle™ plant. Claims for Product appearance defects, however, must be made within 30 days of the date of the shipment from the JM Eagle™ plant. Proof of purchase with the date thereof must be presented to the satisfaction of JM Eagle™, with any claim made pursuant to this warranty. JM Eagle™ must first be given an opportunity to inspect the alleged defective Products in order to determine if it meets applicable industry standards, if the handling and installation have been satisfactorily performed in accordance with JM Eagle™ recommended practices and if operating conditions are within standards. Written permission and/or a Return Goods Authorization (RGA) must be obtained along with instructions for return shipment to JM Eagle™ of any Products claimed to be defective.

The limited and exclusive remedy for breach of this Limited Warranty shall be, at JM Eagle’s sole discretion, the replacement of the same type, size and like quantity of non-defective Product, or credits, offsets or combination of thereof, for the wholesale purchase price of the defective unit.

This Limited Warranty does not apply for any Product failures caused by user’s flawed designs or specifications, unsatisfactory applications, improper installations, use in conjunction with incompatible materials, contact with aggressive chemical agents, freezing or overheating of liquids in the Product, and any other misuse causes not listed here. This Limited Warranty also excludes failure or damage caused by fire stopping materials, tread sealants, or damage caused by the fault or negligence of anyone other than JM Eagle™, or any other act or event beyond the control of JM Eagle™.

JM Eagle’s liability shall not, at any time, exceed the actual wholesale purchase price of the Product. The warranties in this document are the only warranties applicable to the Product and there are no other warranties, expressed or implied. This Limited Warranty specifically excludes any liability for general



damages, consequential or incidental damages, including without limitation, costs incurred from removal, reinstallation, or other expenses resulting from any defect. IMPLIED WARRANTIES OF MERCHANTABILITY OR FITNESS FOR A PARTICULAR PURPOSE ARE SPECIFICALLY DISCLAIMED AND JM Eagle™ SHALL NOT BE LIABLE IN THIS RESPECT NOTWITHSTANDING JM Eagle's ACTUAL KNOWLEDGE OF THE PRODUCT'S INTENDED USE.

JM Eagle's Products should be used in accordance with standards set forth by local plumbing and building laws, codes or regulations and the applicable standards. Failure to adhere to these standards shall void this Limited Warranty. Products sold by JM Eagle™ that are manufactured by others are warranted only to the extent and limits of the warranty of the manufacturer. No statement, conduct or description by JM Eagle™ or its representative, in addition to or beyond this Limited Warranty, shall constitute a warranty. This Limited Warranty may only be modified in writing signed by an officer of JM Eagle™.

## 1.0 RECEIVING AND HANDLING PIPE SHIPMENTS

### 1.1 INSPECTION

Inspect each pipe shipment with care upon arrival. Each pipe shipment is carefully loaded at the factory using methods acceptable to the carrier. The carrier is then responsible for delivering the pipe as received from JM Eagle™. All shipments include an adequate amount of lubricant for the pipe if necessary. IT IS THE RESPONSIBILITY OF THE RECEIVER TO MAKE CERTAIN THERE HAS BEEN NO LOSS OR DAMAGE UPON ARRIVAL.

Check the materials, pipe, gaskets and fittings received against the bill of lading (tally sheet that accompanies every shipment) in accordance with the general guidelines below, report any error or damage to the transportation company representative, and have proper notation made on the delivery receipt and signed by the driver. Present the claim in accordance with the carrier's instructions. Do not dispose of any damaged material. The carrier will advise you of the procedure to follow in order to procure samples and report the incident.

1. MAKE OVERALL EXAMINATION OF THE LOAD. If the load is intact, ordinary inspection while unloading should be enough to make sure pipe has arrived in good condition.
2. IF LOAD HAS SHIFTED OR SHOWS ROUGH TREATMENT, THEN EACH PIECE MUST BE CAREFULLY INSPECTED FOR DAMAGE.
3. CHECK THE TOTAL QUANTITIES OF EACH ITEM AGAINST THE TALLY SHEET (pipe, fittings, lubricant, etc.).
4. ANY DAMAGED OR MISSING ITEMS MUST BE NOTED ON THE DELIVERY RECEIPT AND RETURNED TO THE TRANSPORTATION COMPANY.
5. NOTIFY CARRIER IMMEDIATELY AND MAKE CLAIM IN ACCORDANCE WITH THEIR INSTRUCTIONS.
6. DO NOT DISPOSE OF ANY DAMAGED MATERIAL. Carrier will notify you of the procedure to follow.
7. SHORTAGES AND DAMAGED MATERIALS ARE NOT AUTOMATICALLY RESHIPPED. If replacement material is needed, reorder through your distributor and make them aware of the claim.



**Figure 2**

## 1.2 UNLOADING

JM Eagle's Eagle Corr PE™ is lightweight and may be unloaded by ① Hand (for 18-inch diameter and smaller). ② Conventional forklifts for compact shipping units, palletized bundles in a wood frame which may be used to ship large orders of pipe. Exercise care to avoid impact or contact between the forks and the pipe. The means by which Eagle Corr PE™ pipe are unloaded in the field is the decision and responsibility of the customer. Preferred unloading is in units using mechanical equipment such as forklifts, cranes, cherry pickers or front-end loaders with adequate forks and trained, competent operators and equipment rated to safely handle the load. When unloading units, the instructions below should be carefully followed. Remove only one unit at a time.

1. Follow OSHA Safety Requirements.
2. Remove restraints from the top unit loads. These may be either tiedown straps, ropes or chains with protection. Extreme caution must be used when removing restraints from the shipment. The load may have shifted and could fall from the truck.
3. If there are boards across the top and down the sides of the load that are not part of pipe packaging or secure the load from rolling off the truck, remove them.

4. Use a forklift (or front-end loader equipped with forks) to remove each top unit one at a time from the truck. Remove back units first. Do not run the forks too far under the unit as fork ends striking adjacent units may cause damage, or push other units off the opposite side of truck. Do not let forks rub the underside of pipe to avoid abrasion.
5. If a forklift is not available, a crane or front end loader may be used to unload the pipe. We recommend employing a spreader bar with synthetic straps rated for the load. Lift 36-inch and larger pipe with a sling at two points along the length of the pipe. The straps should be placed approximately 8 feet apart and looped under the load. Cables may be used in place of synthetic straps if they are protected by a rubber hose sleeve to prevent damage to the pipe.
6. DO NOT:
  - a) Handle units with chains or single cables.
  - b) Attach cables to unit frames for lifting.
  - c) Drop pipe or roll the pipe off the truck.
  - d) Use loading forks or forklift directly on the inside of pipe.
7. During the removal and handling, be sure that the units do not strike anything.
8. Units should be stored and placed on level ground. Units should be protected by dunnage in the same way they were protected while loaded on the truck. The dunnage must support the weight of all units so that pipe lengths do not carry the weight of the unit loaded above them. Units should not be stacked more than two high.
9. Non-palletized pipe may be temporarily stockpiled on flat, clear area.
10. To unload lower units, repeat the above unloading process (items 1 through 9).



**Figure 3**

**WARNING:** Corrugated PE pipe, though lighter than other material, is still heavy and may be dangerous if not handled properly. Not adhering to the above instructions may result in serious injury to pipe, property and/or people. Do not stand or climb on units. Stand clear of pipe during unloading.

### 1.3 STOCKPILES

Store pipe on a flat surface so as to support the barrel evenly. Improper storage may deform bells thereby making assembly difficult or may roll a gasket.

If mechanical equipment is being used for handling, the unit bearing pieces provide an excellent base. If unloading by hand, secure two timbers for a base. Set them on a flat area spaced the same as a factory load. Nail chock blocks at each end. Build up the stockpile in the same manner, as it was stacked for shipment, transferring dunnage and chock blocks from load to stockpile. Store random lengths separately where they will be readily available. Individual lengths of pipe should be stacked in piles no higher than 5 feet.

## 1.4 GASKET CARE

All Eagle Corr PE™ pipe is manufactured with factory-installed gaskets. Keep them clean, away from oil, grease, excessive heat and electric motors, which produce ozone. It is advisable to keep gaskets protected from direct sunlight and temperature changes to avoid cracking in prolonged exposure for optimal performance. JM Eagle™ provides a gasket that is approved for sewer service with its standard product. Special gasket types may be available for applications where oil resistance is required. Be sure the correct ring is ordered.

## 1.5 LOADING TRANSFER TRUCKS

Use trucks with long bodies so that pipe lengths do not overhang more than 2 feet. Make certain truck bed is smooth, without cross-strips, bolt heads or other protrusions that could damage the pipe. Avoid sliding the pipe and damaging it.

Short-body trucks may be used if fitted with racks that properly support the pipe in the horizontal position. The rack shall support the pipe with supports spaced every 3 feet or less along the pipe lengths. Pad the contact areas to avoid damage to the pipe.



**Figure 4**

## 1.6 DISTRIBUTING ALONG THE TRENCH

In stringing out pipe, keep these points in mind:

1. Line pipe as near to the trench as possible to avoid excessive handling.
2. If the trench is open, it is advisable to string pipe on the side away from excavated earth wherever possible, so that the pipe can be moved easily to the edge of the trench for lowering into position.
3. If the trench is not yet open, find out which side the excavated earth will be thrown, then string out on the opposite side (leave room for the excavator).
4. Place the pipe so as to protect it from traffic and heavy equipment. Also, safeguard it from the effect of any blasting that may be done.
5. Direct sunlight may cause the exposed side of the pipe to heat up, creating a bow in the pipe. Should this occur, the bow may be alleviated by rotating the cool side toward the sun or by placing the pipe in the shade. Leaving pipe in palletized units minimizes bowing due to heat from the sun.
6. It is normal practice to string pipe with bell ends pointing upgrade.



**Figure 5**

## 2.0 TRENCH CONSTRUCTION

### 2.1 WORKING AHEAD OF THE PIPE LAYING CREW

Where soil and ground water conditions permit, long stretches of trench can be opened ahead of pipe laying, so as to take full advantage of the easy handling and speed of assembly of Eagle Corr PE™ sewer and storm drain pipe. However, as a general rule for most jobs, do not open the trench too far ahead of pipe laying. Avoiding these long stretches of opened trench may help with the economy of the project because:

1. It may reduce or even eliminate pumping or sheeting.
2. It minimizes the possibility of flooding the trench.
3. It reduces caving caused by ground water.
4. It helps avoid frozen trench bottom and backfill.
5. It reduces hazards to traffic and workmen.

On most jobs, it will be desirable to keep excavating, pipe laying and backfilling close together.

### 2.2 CURVES IN THE TRENCH

The trench may be curved to change direction or avoid obstructions within the limits of the curvature of the pipe as described below. Since the moment of inertia of Eagle Corr PE™ pipe is high, attempting to curve the pipe may be difficult. If the pipe barrel cannot be curved, the joints may be deflected to a maximum of 1.5 degrees (or a radius of approximately 760 feet or a 6-inch offset maximum). Offset and radius of curvature is based on a 19.8-foot length of pipe. To accomplish this, the pipe should be assembled in straight alignment and then, with the joint braced, the free end moved laterally using a pry bar or other suitable means. Care should be taken not to exceed the maximum deflection allowed or damage the pipe with the machinery used. Abrupt changes in direction may be accomplished with fittings.



**NOTICE:** AVOID OVER-STRESSING THE BELL OR PIPE WALL (over-inserting the joints, or exceeding the maximum deflection allowed) IN ORDER TO PREVENT POSSIBLE BREAKAGE AND/OR LEAKS.

## 2.3 TRENCH WIDTHS

In general pipe diameter, backfill material, compaction equipment and native soils all influence the minimum trench width. Trench widths should be kept to a minimum to avoid excessive excavation cost. However, trench widths must be sufficient for adequate backfill compaction, compaction equipment and safety equipment. The trench width at the ground surface may vary with and depend upon depth, type of soils and position of surface structures. The minimum clear width of the trench, sheeted or unsheeted, measured at the spring-line of the pipe should be 1 foot greater than the outside diameter of the pipe. The maximum clear width of the trench at the top of the pipe should not exceed a width equal to the pipe outside diameter plus 2 feet. This spacing will allow for proper compacting of the backfill to provide necessary sidewall support. If the above-defined trench widths must be exceeded or, if the pipe is installed in a compacted embankment, pipe embedment should be compacted to a point of at least 2.5 pipe diameters from the pipe on both sides of the pipe or to the trench walls, whichever is less. The minimum recommend trench widths are shown in [Table 1](#). Please note that these trench widths are recommendations only and the does not supersede requirements specified by the project engineer.

**NOTICE:** The trench width recommendations above are to help installers realize the economies that may result from installation of Eagle Corr PE™ pipe over other materials, while maintaining adequate control over backfilling, compaction, and placement to limit long-term deflection.

MINIMUM TRENCH WIDTHS		
NOMINAL ID IN (MM)	AVERAGE OD IN (MM)	MINIMUM TRENCH WIDTH <sup>1</sup> IN (M)
4 (100)	5 (120)	21 (0.5)
6 (150)	7 (174)	23 (0.6)
8 (200)	9 (231)	25 (0.6)
10 (250)	11 (290)	27 (0.7)
12 (300)	14 (363)	30 (0.8)
15 (375)	17 (444)	34 (0.9)
18 (450)	21 (529)	38 (1.0)
24 (600)	28 (699)	46 (1.2)
30 (750)	35 (880)	55 (1.4)
36 (900)	42 (1055)	64 (1.6)
42 (1050)	47 (1204)	71 (1.8)
48 (1200)	54 (1367)	79 (2.0)
60 (1500)	67 (1693)	95 (2.4)

**Table 1**

## 2.4 TRENCH DEPTHS

Depth is governed by surface loads, earth loads and backfill material. A minimum of 12 inches depth of cover is recommended for diameters 48 inches and smaller and a minimum of 24 inches for 60 inches diameter pipe.

For more information on minimum and maximum burial depths and deflection, see [Table 14](#) on page 57.

## 2.5 PREPARATION OF TRENCH BOTTOM

The trench bottom should be smooth and free from stones greater than 1.5 inches in diameter, large dirt clods and any frozen material. Excavation should be provided so that the pipe is uniformly supported along its length. For details regarding the foundation for the trench bottom, pipe bedding and initial backfill around the pipe, see [Section 4](#) of the manual.

## 2.6 TRENCH SAFETY, TRENCH BOXES AND SHEETING

Trenches can be dangerous and the contractor has the responsibility of ensuring that all safety regulations and design requirements have been observed for the protection of the workers and the public. OSHA requirements should always be followed when using a trench box.

The length of the trench box should be suitable for the pipe length. The most effective trench configuration is the subtrench method as shown in [Figure 6](#). This subtrench method is effective in maintaining the integrity of the backfill and compaction, while meeting safety requirements. The maximum recommended subtrench is 24 inches, as shown in [Figure 6](#). Backfill and compact within the subtrench should be in accordance with the design specifications. The trench box can be pulled along the top of the subtrench without affecting the pipe or the backfill.

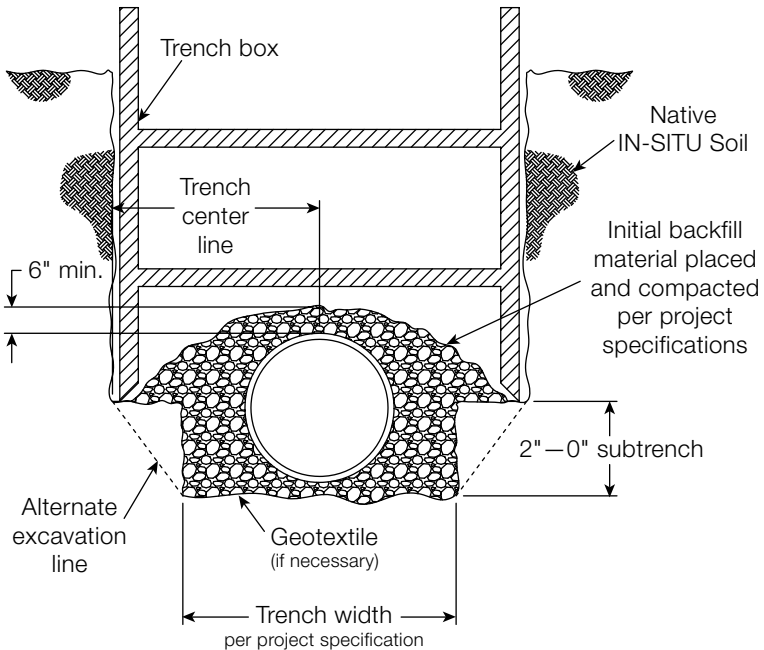

**Figure 6**

When sheeting is used, it should be left in place unless it is designed to prevent disturbing the soil adjacent to the pipe when pulled and removed. If heavy wooden sheeting has to be pulled, well-graded granular material should be placed on each side of the pipe for a distance of at least two pipe diameters. The granular material should be compacted to at least 90 percent Standard Proctor Density.

Whenever possible, sheeting and bracing should be installed so that the bottom of the sheeting extends no lower than the spring-line or 2 feet from the bottom of the pipe (whichever is less). When installed in this manner, pulling the sheeting will minimize disturbance of the initial backfill material, which provides sidewall support for the pipe. If a trench box is used, it should be designed so that the backend of the sides do not extend below 2 feet above the bottom of the pipe. This will allow filling and compaction of the annular space as the trench box is moved forward.

It should be noted that OSHA standards change from time to time. In the event any of these recommendations are in conflict with OSHA standards or specific site conditions warrant alternative safety precautions, contact a qualified engineer.



**Figure 7**

## 3.0 PIPELINE CONSTRUCTION

### 3.1 INSPECTION

Pipe and fittings should be inspected for defects or damage prior to lowering into the trench. Any defective, damaged or unsound pipe should be repaired or replaced and all foreign matter or soil should be removed from the interior of the pipe and fittings, before lowering into the trench. If any corrugations are damaged. See [Section 1](#), “Receiving and Handling Pipe Shipments,” for a determination of pipe service ability.

### 3.2 LOWERING PIPE AND ACCESSORIES INTO TRENCH

All pipe, fittings, valves and accessories should be carefully lowered into the trench using suitable equipment in such a manner as to prevent damage to pipe and accessories. PIPE AND ACCESSORIES SHOULD NEVER BE DROPPED OR DUMPED INTO THE TRENCH.

DO NOT use chains or cables for lowering Eagle Corr PE™ into the trench unless they are padded in some way to prevent damage to the pipe. We recommend using nylon strap slings.

### 3.3 ASSEMBLY OF EAGLE CORR PE™

Eagle Corr PE™ uses bell-and-spigot connections. It is imperative that the joint be assembled properly to ensure performance to expectations. Make certain that both the bell and spigot are clean and have no foreign matter that could prevent an effective seal between the gasket and bell surfaces. Eagle Corr PE™ gasket rings are shipped on the spigot and wrapped with a protective wrap to prevent loss or damage of the ring. (See [Figure 8](#)).

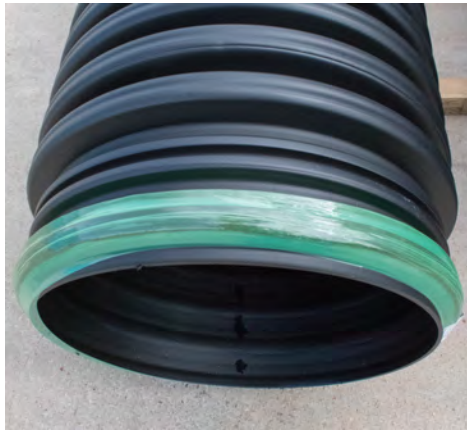

**Figure 8**

**Important:** If for any reason the gasket must be placed on the pipe in the field, make sure that the gasket ring is seated flatly in the tapered corrugation groove on the spigot end of the pipe. For both soiltight and watertight (10.8 psi) connections, place one gasket ring in the outer tapered corrugation groove. See [Figure 9](#) for a picture of the spigot end piece of Eagle Corr PE™ watertight/soiltight pipe with single gasket.



**Figure 9**

## JOINT ASSEMBLY

1. Lower the pipe into trench by hand or use a nylon strap and excavating equipment.
2. Inspect the bell and remove foreign matter such as stones and dirt (if any). Foreign matter lodged between the gasket and the bell sealing surface could cause a leak in the joint.
3. Use a clean brush, cloth rag, sponge or gloved hand to lubricate bell with a thin layer of lubricant. Be sure to cover the full circumference
4. Remove protective wrap from gasket(s).
5. Clean spigot end of pipe.
6. Use a clean brush, cloth rag, sponge or gloved hand to lubricate gasket(s). See [Figure 10](#).
7. Do not allow lubricated sections to contact dirt or backfill. Foreign matter could stick to the surface and compromise joint integrity.
8. Insert the spigot end into the bell.

**Note:** Always push the spigot end into the bell end. Pushing the bell onto the spigot may scoop dirt, backfill and/or foreign matter into the bell and compromise the pipe joint.



**Figure 10**

## PIPE JOINT HOMING METHODS

Pipe joint homing can be achieved by one of the following methods:

1. Bar and Block Method
2. Excavator Method
3. Excavator & Sling Method

### Bar and Block Method

Small 4-inch to 18-inch diameter Eagle Corr PE™ pipe can be assembled by using the bar and block method.

1. With the pipe trench bedding properly prepared and the pipe properly supported, drive the steel bar into the trench bottom.
2. Place a wood block into the bell end of the pipe. (The wood block protects the pipe against damage by the bar.)
3. With the bar, push against the wooden block until the spigot is pushed into the bell. Stop pushing together when the factory-applied stop mark on the spigot is flush with the end of the bell. See [Figure 11](#).

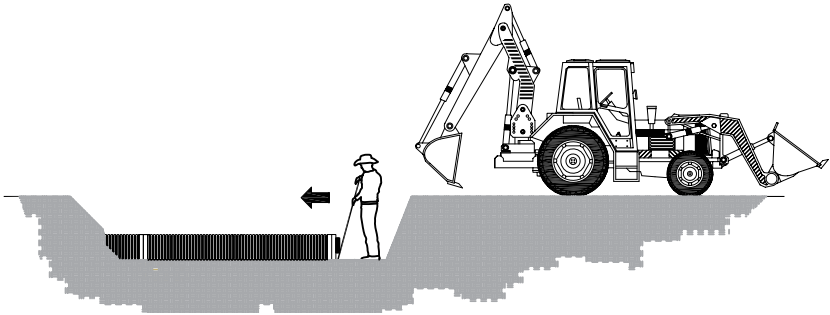

**Figure 11**

### Excavator and Sling Method

Excavator and Sling Method can be used on all sizes of pipe, but is most commonly used for 24-inch and greater diameters of pipe.

1. With the pipe trench bedding properly prepared, wrap a nylon sling around the pipe. One pack-up point is typically used for pipe less than



36 inches in diameter and two pick-up points is recommended for 36-inch and larger pipe.

2. Attach the other end of the nylon sling to the backhoe bucket.
3. The operator should carefully pull the strap tight toward the bell of the downstream pipe.
4. The operator should pull the pipe spigot until it is fully inserted into the bell and reaches the homing mark. Caution should be exercised not to over home the pipe.
5. The operator should ensure the pipe spigot is inserted squarely into the bell to avoid misalignment. As a rule of thumb, the distance between the bedding and the bell end of the pipe in the sling should not be off the ground more than 0.5 feet for a 20-foot length of pipe (see [Figure 12.](#)) That distance will decrease for shorter lengths of pipe.

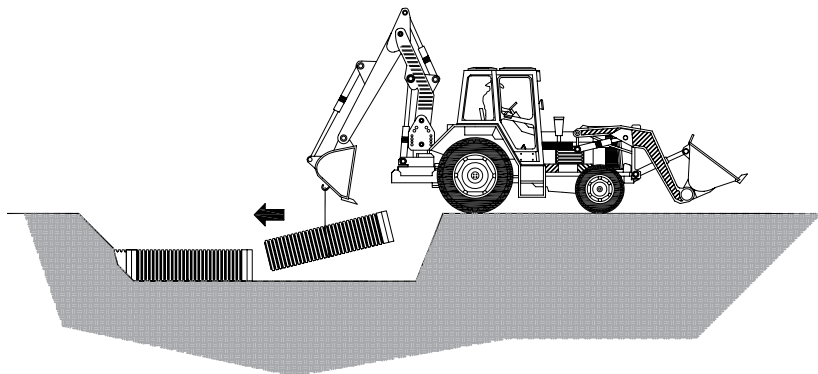

**Figure 12**

### Excavator Method

Excavator Method can be used on all sizes of pipe, but is most commonly used for 24-inch and greater diameters of pipe.

1. With the pipe trench bedding properly prepared, lower the pipe into the trench.
2. Prepare the bell and spigot with lubricant as required.
3. Place an installation stub into the bell of the pipe being assembled (see [Figure 14.](#))

4. Place a wooden block across installation stub.
5. Push back of excavator bucket against block until the pipe is full inserted into the bell and is homed. Caution should be exercised not to over home the pipe.

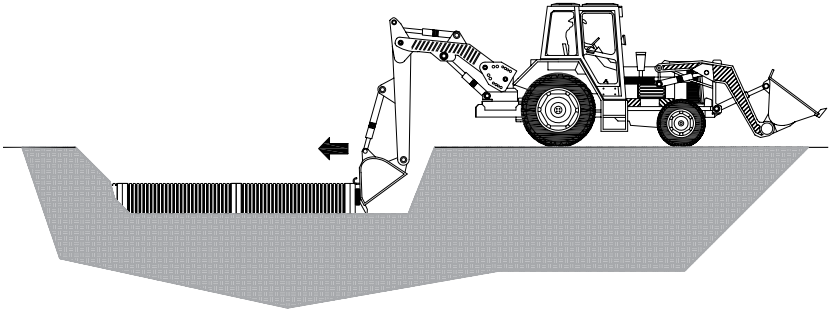

**Figure 13**

**CAUTION:** While attempting assembly, be sure the pipe lengths are in straight alignment and not misaligned vertically or horizontally. Improper alignment will cause a difficult or impossible assembly. If pipe must be misaligned in line or grade, it can be done after assembly is completed. Such misalignment should not exceed 1.5 degrees at each joint. Also, note that excessive misalignment or an over-assembled joint can cause leaks.

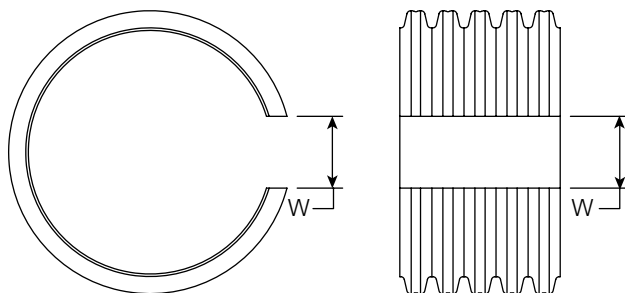

**Figure 14**

Installation Stub Field Fabrication

Fabrication of an installation stub is necessary to prevent inadvertent damage while assembling the pipe joint. If the bell is not pushed on during the assembly process an installation stub is not necessary. An installation stub can be fabricated on the job site in two ways.

1. If a spigot of pipe (from the same diameter of pipe being assembled) is available, a short section of the spigot can be inserted into the bell and used as an installation stub. At a minimum, this short section of the spigot will be cut in the valley of the fifth corrugation from the spigot end of the pipe.
2. A second method of fabricating an installation stub uses a short section of pipe five full-size corrugations long. (*Note: The outside diameter of the spigot corrugations are smaller than the outside diameter of the full size corrugations along the barrel of the pipe*). Both ends of the pipe should cut in the valley of the corrugations. Fabricating this installation stub requires saw cutting a predefined width of the pipe ( $W$ ) along the length of the short section of pipe (see [Figure 15](#)). The width of the saw cut is dependent on the diameter of the pipe and is summarized in [Table 2](#). Once the section of pipe is removed, the cut section can be pushed together and inserted into a bell.



**Figure 15**

INSTALLATION STUB CUT WIDTHS	
DIAMETER(S) IN (MM)	WIDTH IN (MM)
4 – 6 (100 – 150)	2 (50)
8 (200)	2.5 (65)
10 – 12 (250 – 300)	4 (100)
15 (375)	5 (125)
18 (450)	6 (150)
24 (600)	7.5 (190)
30 – 42 (750 – 1050)	10 (254)
48 – 60 (1200 – 1500)	12 (300)

**Table 2**

### Field Cuts and Jointing Pipe

It is easier and safer to cut pipe to the exact length before it is placed in the trench. A hand saw with “cross cut” teeth is recommended for cutting Eagle Corr PE™. Because of the unique design Eagle Corr PE™, it is recommended to cut the pipe between the corrugations. Simply measure the required length from the pipe end and cut at the mid-point between the ribs as shown in [Figures 16](#) and [17](#).

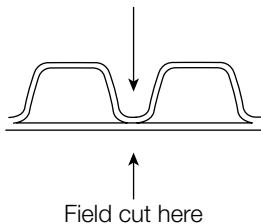

**Figure 16**

**Note:** If an abrasive saw is used to cut Eagle Corr PE™ pipe, safety goggles should be worn by the saw operator to protect eyes from pipe chips.



**Figure 17**

When Eagle Corr PE™ must be field cut to fit a specific application, the following instructions will ensure proper performing joints:

1. Remove the reduced spigot from the pipe (8-inch-diameter or larger). Cut in the center of the valley of the first full corrugation.
2. Trim remaining polyethylene burrs from saw cut.  
**Note:** Failure to smoothly trim burrs may compromise joint integrity.
3. Remove dirt and debris from the valley for the first corrugation at the cut end of pipe. (*This is where gasket will be placed.*)
4. Remove gasket from plastic bag.
5. Hold gasket with both hands so printing is facing you.
6. Slide valley gasket into first corrugation valley, starting at the bottom so that the gasket label is upright and readable from the cut end of the pipe.  
**Note:** It is easier to place gasket in the valley at the bottom of the pipe and pull up to conform to the valley. (See [Figure 18](#).)
7. Slide gasket into first corrugation valley by hand.
8. Ensure printing on gasket is face-up and toward spigot end of pipe.

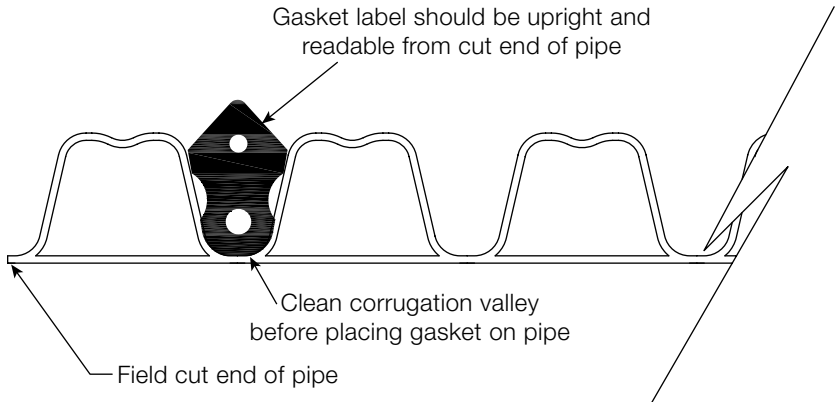

**Figure 18**

**Note:** Gasket shown for illustrative purposes. Actual gasket size and shape may vary.

To assemble Eagle Corr PE™ use only the JM Eagle™ approved lubricant supplied, based on normal conditions. Extra lubricant needed for adverse conditions must be ordered separately. Lubricant is supplied for pipe and fittings based on the number of spigot ends involved.

### 3.3.1 LUBRICANT REQUIREMENTS

The following table gives the number of pipe joints that can be assembled using a 1-quart container of lubricant for Eagle Corr PE™ pipe. See [Table 3](#).

PIPE SIZE		JOINTS/1 LB OF LUBRICANT
INCHES	MM	
8	200	15
10	250	12
12	300	9
15	375	6
18	450	4+
24	600	4
30	750	3+
36	900	3
42	1050	2+
48	1200	2
60	1500	1+

**Table 3**

### 3.4 CATCH BASIN AND MANHOLE STRUCTURES

Structures vary by locality with brick, concrete blocks, pre-cast concrete and PVC units most commonly being used. Catch basins are typically used to collect surface runoff from developed parcels of land, while manhole structures are typically used to change pipe size, pipe material, direction, grade and elevation. For commercial developments, PVC or HDPE catch basins are preferred. Concrete does not bond to HDPE pipe.

Regardless of the type of structure or type of pipe being connected to, there are basic engineering areas of concern: differential settlement between the pipe and the structure, and the connection between the pipe and structure. Addressing these two concerns with proper installation techniques helps ensure that the system will meet long term expectations. Proper installation techniques to address these concerns are addressed in the next few paragraphs.

#### 3.4.1 TRANSITIONS TO MANHOLES, CATCH BASINS AND





## AND OTHER STRUCTURES

The connection between the any type of pipe and structures is also critical to meeting long-term expectations. Poor connections between pipe and structures may allow soil to infiltrate into the structure and water to exfiltrate out of the structure. This movement of materials creates voids and contributes to sink holes and differential settlement of the structure. The type of connection required depends onsite conditions that include water table, system surcharge and in-situ soils. Additionally the types of connections may be dictated logistical constraints that may require field fabrication of a reliable joint. The following paragraphs describe five of the most commonly recognized methods of connecting pipe to structures for stormwater sanitary sewer and irrigation applications.

### SOIL-TIGHT

The grouted field fabricated connection is a soil-tight connection. This connection is illustrated in [Figure 20](#). This type of connection is one of the simplest and most reliable connection. The corrugations grouted with a non-shrink cementitious grout form a soil-tight seal with the corrugations locking into the grout. This connection is field fabricated and is soil tight.

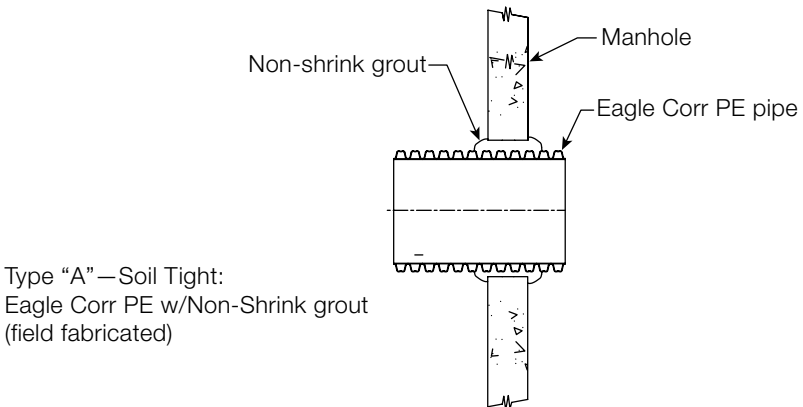

**Figure 20**

### WATERTIGHT

Cement does not adhere to HDPE. Therefore, gaskets are inserted into the valley of the corrugations passing through the structure wall. The valley gasket will serve as a waterstop. The pipe and gasket are then grouted in place with a non-shrink cementitious grout. Special attention must be given to ensuring the grout is well placed. A detail of this connection is shown in Figure 21.

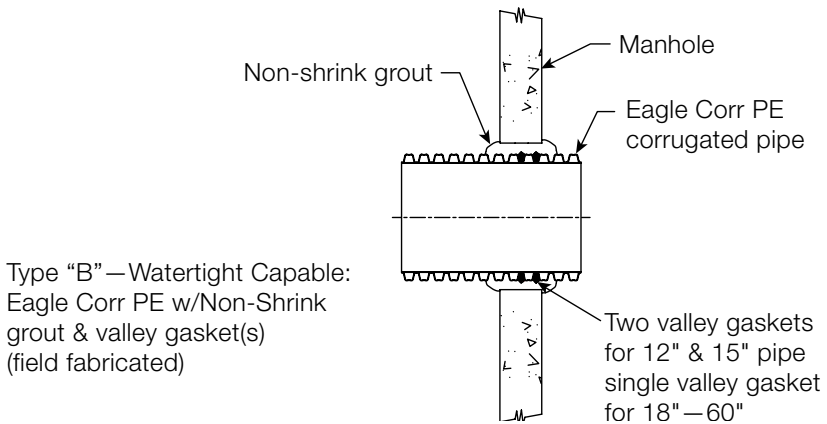

Type “B” — Watertight Capable:  
Eagle Corr PE w/Non-Shrink  
grout & valley gasket(s)  
(field fabricated)

**Figure 21**

## BOOTED MANHOLE CONNECTIONS

Those are also used for drainage applications and are typically the preferred method for sanitary sewer applications. The booted manhole connection is used for making flexible boot connections to a structure. This Type “C” connection is shown in Figure 22. The booted connection requires a prefabricated a smooth manhole adaptor, which has a smooth exterior. This smooth exterior enables the boot to have flat surface to seal against. To order the smooth manhole adaptor from JM Eagle™, specify the pipe diameter.

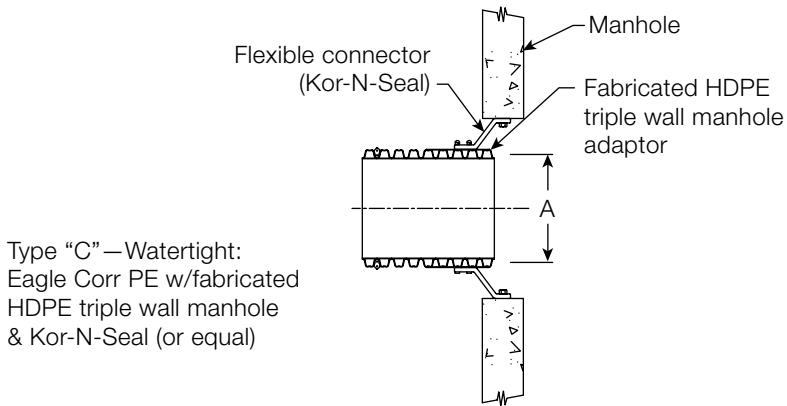

**Figure 22**

When ordering the flexible boot connection refer to the Smooth Manhole Adaptor outside diameter listed in [Table 4](#). Contact the flexible boot connection supplier for product recommendations.

PIPE SIZE		MANHOLE ADAPTOR O.D.	
INCHES	MM	INCHES	MM
8	200	9.4	239.1
10	250	11.7	297.5
12	300	14.6	371.20
15	375	17.8	452.40
18	450	21.1	536.30
24	600	27.8	706.40
30	750	35.2	893.10
36	900	42.1	1,068.40
42	1050	48.2	1,224.60
48	1200	54.6	1,387.20
60	1500	67.5	1,714.80

**Table 4**

### A-LOK™ STYLE MANHOLE CONNECTIONS

Where manholes are manufactured with A-Lok's use the "smooth" manhole adaptor is recommended. This Type "D" connection is shown in [Figure 23](#).

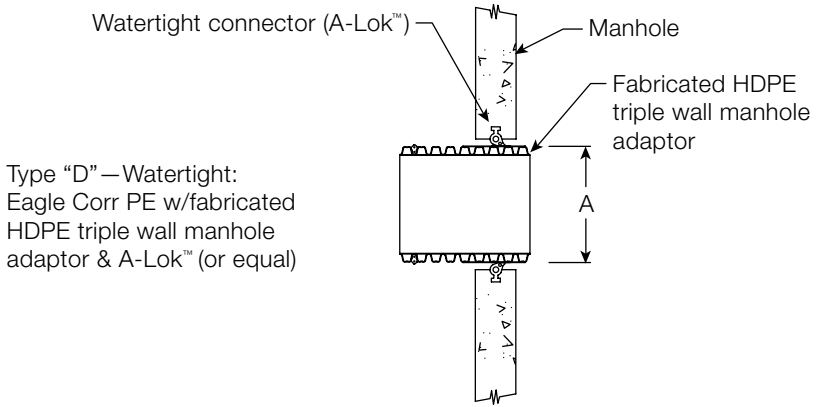

Type "D" — Watertight:  
Eagle Corr PE w/fabricated  
HDPE triple wall manhole  
adaptor & A-Lok™ (or equal)

**Figure 23**

The A-Lok™ should be sized based on the Smooth Manhole Adaptor outside diameter. Contact A-Lok™ for the recommended A-Lok™ product.

## BOOTED FIELD FABRICATED CONNECTION

To field fabricate a booted watertight field connection, a valley gasket is placed on the pipe and a full corrugation bell is placed on the pipe to form a smooth exterior. The rubber boot is then tightened on to the bell outside diameter. See [Figure 24](#).

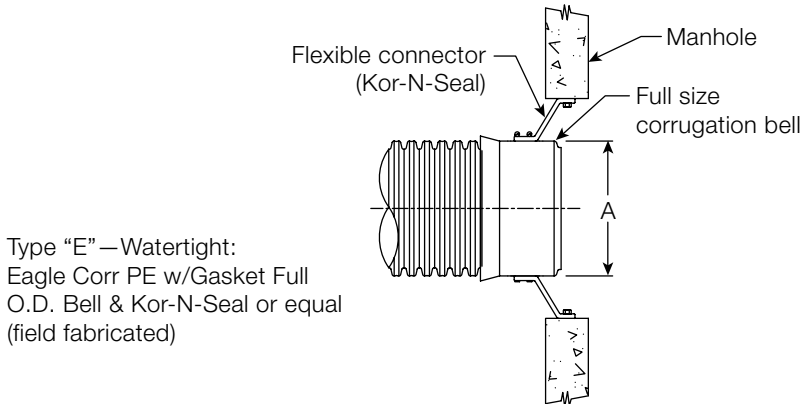

Type "E" — Watertight:  
Eagle Corr PE w/Gasket Full  
O.D. Bell & Kor-N-Seal or equal  
(field fabricated)

**Figure 24**

## 4.0 PIPE EMBEDMENT

Understanding flexible conduit terminology is essential for the installer. The soil class and density realized in the bedding, haunching and initial backfill, as well as the manner and care with which they are placed, are important factors in achieving a satisfactory installation of a flexible conduit. Over-deflection, when it occurs, is invariably the result of improper compaction in the haunching area. [Figure 25](#) is an illustration of a typical trench with all major regions identified, as they will be addressed in the following sections.

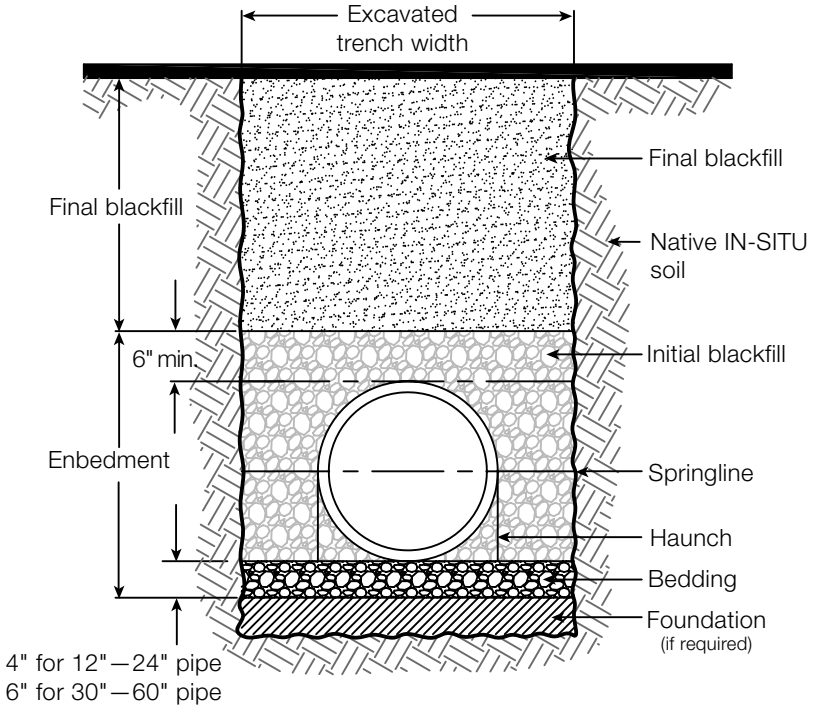

**Figure 25**

#### 4.1 PREPARATION OF THE TRENCH BOTTOM

The trench floor should be constructed to provide a firm, stable and uniform support for the full length of the pipe. This can be accomplished by bringing the entire trench floor to a level grade to permit proper joint assembly, align-

ment, and support. Portions of the trench that are excavated below grade should be returned to grade and compacted as required to provide proper support. If the native trench soil is not suitable for the pipe bedding, the trench should be over excavated and refilled with suitable foundation material as specified by the engineer. A cushion of acceptable bedding material should always be provided between any hard foundation and the pipe. Large rocks, boulders, and stones should be removed to allow a minimum of 4 inches of soil cushion on all sides of the pipe and accessories.

## 4.2 TRENCH EXCAVATION

The minimum width of a trench to insure the proper installation of a buried conduit depends on the pipe diameter, embedment material and compaction requirements. Trench widths for small diameter pipes are typically determined by standard excavator bucket sizes. Trenches that are too narrow do not allow for the proper amount and compaction of embedment material in the haunch zones, while trenches that are too wide result in unnecessary costs. Recommended minimum trench widths per ASTM D2321 are shown in Table 5.

MINIMUM TRENCH WIDTHS		
NOMINAL ID IN (MM)	AVERAGE OD IN (MM)	MINIMUM TRENCH WIDTH <sup>1</sup> IN (M)
4 (100)	5 (120)	21 (0.5)
6 (150)	7 (174)	23 (0.6)
8 (200)	9 (231)	25 (0.6)
10 (250)	11 (290)	27 (0.7)
12 (300)	14 (363)	30 (0.8)
15 (375)	17 (444)	34 (0.9)
18 (450)	21 (529)	38 (1.0)
24 (600)	28 (699)	46 (1.2)
30 (750)	35 (880)	55 (1.4)
36 (900)	42 (1055)	64 (1.6)
42 (1050)	47 (1204)	71 (1.8)
48 (1200)	54 (1367)	79 (2.0)
60 (1500)	67 (1693)	95 (2.4)

**Table 5**

<sup>1</sup> Minimum trench width per ASTM D2321 = greater of OD+16" or 1.25×OD+12".

## 4.3 PIPE LAYING

Proper implements, tools and equipment should be used for placement of the pipe in the trench to prevent damage. Avoid dropping pipe and accessories into the trench, as this may cause damage that is not easily detected. Additional handling instructions may be sought from our product installation guides or by contacting JM Eagle™. In general, pipe laying should begin at the lowest point and work toward manholes, service branches or clean-outs. Pipe bells can be laid in either direction, upstream or downstream without any significant hydraulic loss. However, common practice is to lay the bells in the direction of work progress to ease installation. Additionally, by inserting the spigot into the bell rather than pushing the bell over the spigot, the risk of soil or rubble being scooped under the gasket is reduced. If pipe laying is interrupted or halted, the exposed ends of the pipeline should be closed to prevent the entrance of trench water, mud and foreign matter.

#### 4.4 FOUNDATION

A foundation is required when the trench bottom is unstable. Any foundation that will support a rigid pipe without causing loss of grade or flexural breaking will be more than adequate for Eagle Corr PE™ pipe.

In cases where muck, peat or other soft material form the foundation, there is a potential for the pipe to settle and loose grade. In cases where rock, rock protrusions or unyielding material form the foundation, there is a potential for a point load on the pipe or fittings. Both of these cases may affect hydraulics and/or structural integrity of the system. It is recommended the trench bottom be over excavated and replaced with a suitable foundation, as specified by the design or geotechnical engineer when these cases exist.

#### 4.5 BEDDING

Bedding is required primarily to bring the trench bottom up to grade. Bedding materials should be placed to provide uniform longitudinal support under the pipe to prevent low spots. Blocking should not be used to bring the pipe to grade. Under normal circumstances, a bedding of 4 inches to 6 inches compacted is of sufficient thickness for the bedding. The middle portion of the bedding (equal to one-third of the pipe's outside diameter) should be

loosely placed to provide uniform support at the invert. Acceptable bedding materials include Class I, II, or III materials as defined in [Table 6](#).

If the native in-situ soil is comprised of fine grain soils and migration of those soils into the bedding material is anticipated, precautions should be taken to eliminate or reduce the potential for soil migration. Acceptable methods to minimize the potential for soil migration include, but are not limited to, nonwoven geotextile layer, use of acceptable bedding material with fines that fill potential migration sites or other acceptable method to avoid compromising the trench backfill materials as specified by the engineer.

Bell holes are used to maintain the grade of the pipe in cases where the pipe fitting or coupler is greater than the outside diameter of the pipe. Properly formed bell holes should not be over excavated and should provide uniform longitudinal support for the pipe.

#### 4.6 INITIAL BACKFILL

Initial backfill is critical since it provides support to the pipe to resist soil and live loads. Initial backfill begins from the bottom of the pipe to a level of 6 inches above the top of the pipe. This material and minimum required compaction level should be on the construction plans and will take precedence on the project site. Provided the plans meet minimum recommendations, backfilling should follow trench excavation pipe assembly as closely and safely as possible. Backfilling after pipe assembly eliminates the possibility of lifting the pipe from grade due to flooding of an open trench, avoids shifting pipe out of line by cave-ins, and in cold weather lessens the possibility of backfill material's becoming frozen.

Placement of the initial backfill is a critical part of the installation operation. Typically, backfill material is placed in the center of the pipe allowing material to fall on each of the pipes to keep soil pressure evenly distributed. Even distribution of soil pressure during the initial backfill operation keeps the pipe aligned in the trench. In-situ or local material may be acceptable for backfill, however, it is necessary that locally available material meet the soil classifications outlined in [Table 6](#). Minimum compaction levels, lift depths and backfill material quality requirements are shown in [Table 6](#) as well.



PIPE BEDDING, BACKFILL AND EMBEDMENT MATERIAL						
DESCRIPTION	ASTM D2321 <sup>(1)</sup>	ASTM D2487 <sup>(1)</sup>	AAASHTO M145 NOTATION	MIN. STD. PROCTOR DENSITY (%)	LIFT PLACEMENT DEPTH <sup>(6)</sup>	
Clean manufactured crushed rock, angular with particle faces fractured. Angular crushed stone or rock, crushed gravel, crushed slag, stone/sand mixtures with ≤ 12% fines.	I	N/A	—	Dumped	18" (0.5m)	
Clean, coarse-grained soils, gravels, clean gravels, gravel/sand mixtures; Well-graded sands, gravelly sands.	II	GW <sup>(2)</sup> , GP, SW, SP	A1, A3	85%	12" (0.3m)	
Coarse-grained soils with fines, gravels with fines, clean sands, sands with fines, sandy or gravelly fine-grained soils.	III	GM <sup>(3)</sup> , GC, SM, SC	A-2-4, A-2-5, A-2-6, or A-4, or A-6 w/≤30% retained on #200 sieve	90%	9" (0.2m)	
Fine grained soils, silts and clays, inorganic fine-grained soils; inorganic silts and very fine sands, rock flour, silty or clayey fine sands, silts with slight plasticity.	IV	ML, CL	A-2-7 or A-4 or A-6 w/≥ 30% retained on #200 sieve	N/R <sup>(4)</sup>	N/R	
Inorganic silts and clays, fine sandy or silty soils; organic or highly organic soils; organic silts and organic silty clays of low plasticity; organic clays of medium to high plasticity, organic silts; peat and other high organic soils.	V	MH, CH, OL, OH, PT	A5, A7	N/R	N/R	

Table 6

**RECOMMENDATIONS FOR INSTALLATION AND USE OF SOILS AND AGGREGATES FOR FOUNDATION, EMBEDMENT AND BACKFILL.**

**SOIL CLASS AS DEFINED IN TABLE 6**

	<b>CLASS IA</b>	<b>CLASS IB</b>	<b>CLASS II</b>	<b>CLASS III</b>	<b>CLASS IV-A</b>
<b>GENERAL RECOMMENDATIONS AND RESTRICTIONS</b>	Do not use where conditions may cause migration of fines from adjacent soil and loss of pipe support. Suitable for use as a drainage blanket and underdrain in rock cuts where adjacent material is suitably graded.	Process materials as required to obtain gradation which will minimize migration of adjacent materials. Suitable for use as drainage blanket and underdrain.	Where hydraulic gradient exist check gradation to minimize migration. "Clean" groups suitable for use as drainage blanket and underdrain.	Do not use where water conditions in trench may cause instability.	Obtain geotechnical evaluation of processed material. May not be suitable under high earth fills and surface applied loads or under heavy vibratory compactors and tampers. Do not use where water conditions in trench may cause instability.
<b>FOUNDATION</b>	Suitable as foundation and for replacing over-excavated and unstable trench bottom as restricted above. Install and compact in 6-inch maximum layers.	Suitable as foundation and for replacing over-excavated and unstable trench bottom. Install and compact in 6-inch maximum layers.	Suitable as foundation and for replacing over-excavated and unstable trench bottom as restricted above. Install and compact in 6-inch maximum layers.	—	Suitable only in undisturbed conditions and where trench is dry. Remove all loose material and provide firm, uniform trench bottom before bedding is placed.

<b>BEDDING</b>	Suitable as restricted above. Install in 6-inch maximum layers. Level final grade by hand. Minimum depth 4 inches (6 inches in rock cuts).	Install and compact in 6-inch maximum layers. Level final grade by hand. Minimum depth 4 inches (6 inches in rock cuts).	Suitable as restricted above. Install and compact in 6-inch maximum layers. Level final grade by hand. Minimum depth 4 inches (6 inches in rock cuts).	Suitable only in dry trench conditions. Install and compact in 6-inch maximum layers. Level final grade by hand. Minimum depth 4 inches (6 inches in rock cuts).	Suitable only in dry trench conditions and compaction control is maintained. Install and compact in 6-inch maximum layers. Level final grade by hand. Minimum depth 4 inches (6 inches in rock cuts).
<b>HAUNCHING</b>	Suitable as restricted above. Install in 6-inch maximum layers. Work in around pipe by hand to provide uniform support.	Install and compact in 6-inch maximum layers. Work in around pipe by hand to provide uniform support.	Suitable as restricted above. Install and compact in 6-inch maximum layers. Work in around pipe by hand to provide uniform support.	Suitable as restricted above. Install and compact in 6-inch maximum layers. Work in around pipe by hand to provide uniform support.	Suitable only in dry trench conditions and compaction control is maintained. Install and compact in 6-inch maximum layers. Work in around pipe by hand to provide uniform support.
<b>INITIAL BACKFILL</b>	Suitable as restricted above. Install to a minimum of 6 inches above pipe crown.	Install and compact to a minimum of 6 inches above pipe crown.	Suitable as restricted above. Install and compact to a minimum of 6 inches above pipe crown.	Suitable as restricted above. Install and compact to a minimum of 6 inches above pipe crown.	Suitable as restricted above. Install and compact to a minimum of 6 inches above pipe crown.
<b>FINAL BACKFILL</b>	Compact as required by the engineer.	Compact as required by the engineer.	Compact as required by the engineer.	Compact as required by the engineer.	Suitable as restricted above. Compact as required by the engineer.

**Table 7**

**Note:** See section 4.8.5 for clarification Class IV-A materials as embedment material for flexible conduits.

**Notes for Table 6:**

1. See ASTM D 2321 or D2487 for detailed description and classification of material.
2. Also includes materials that begin with SW, SP, GW, GP and less than or equal to 12 percent fines.
3. GM, GC, SM, SC or any soil beginning with one of these symbols containing > 12 percent passing #200 sieve; CL, ML or any soil beginning with one of these symbols with less than or equal to 12 percent retained on #200 sieve.
4. Not recommended for pipe applications. Some Class IV material may be used under special circumstances and under the direct supervision of a design or geotechnical engineer.
5. Layers should not exceed half the pipe diameter. Layer heights may need to be reduced to accommodate compaction methods.

As with the bedding, it is important to prevent the migration of soils. The migration soil between bedding and initial backfill and between the initial backfill can affect the structural integrity of the installed system. If different materials are used or there is the potential for soil migration, precaution such as nonwoven geotextile layer, use of acceptable bedding material with fines that fill potential migration sites, or other acceptable method to avoid compromising the trench backfill materials as specified by the engineer should be taken.

## 4.7 HAUNCHING



**Figure 26**

The haunching area is the most important in terms of limiting the deflection of a flexible pipe. The haunch area is illustrated in [Figure 25](#). The haunching should be placed in 4- to 6-inch lifts and compacted in accordance with [Table 8](#). Because of the shape of the pipe and space restrictions in the trench, special care must be taken to fill any voids and obtain proper compaction in the haunch area. [Figures 27 and 28](#) illustrate correct and incorrect initial backfill placement in the haunch area.

### Correct backfill

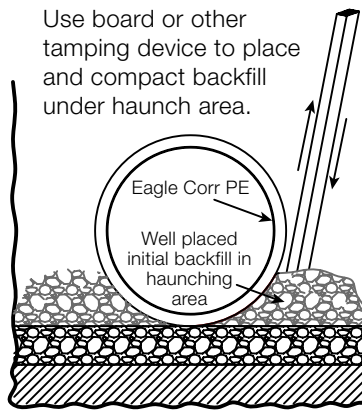

Figure 27

### Incorrect backfill

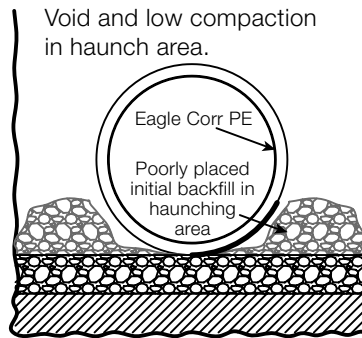

Figure 28

## 4.8 EMBEDMENT MATERIALS

Materials suitable for foundation and embedment are classified in the [Tables 6](#) and [7](#). They include a number of processed materials plus soil types defined according to the Unified Soil Classification System in ASTM D2487, “Standard Method for Classification of Soils for Engineering Purposes.” [Table 7](#) provides recommendations on the installation and use based on class of soil or aggregates and location within the trench. It is important to engineer all materials used in the pipe trench to work together and with the native material surrounding the trench.



**Figure 29**

#### 4.8.1 CLASS IA MATERIALS

Class IA materials provide the maximum stability and pipe support for a given density because of the angular interlocking of the material particles. With minimum efforts, these materials can be installed at relatively high densities over a wide range of moisture contents. These materials also have excellent drainage characteristics that may aid in the control of water. These soils are often desirable as embedment in rock cuts where water is frequently encountered. On the other hand, when ground water flow is anticipated, consideration should be given to potential migration of fines from adjacent materials into the open graded Class IA materials.

#### 4.8.2 CLASS IB MATERIALS

These materials are produced by mixing Class IA and natural or processed sands to produce a particle-size distribution that minimizes migration from surrounding soils that may contain fines. They are more widely graded than Class IA and thus require more compaction effort to achieve the minimum density specified. When these materials are properly compacted, these soils exhibit high stiffness and strength, and depending on the amount of fines, may be relatively free draining.

#### 4.8.3 CLASS II MATERIALS

When Class II materials are compacted they provide a relatively high level of pipe support. In most respects, they all have the desirable characteristics of Class IB materials when widely graded. However, open-graded groups may allow for migration and the sizes should be checked for compatibility with the native trench materials. Typically, Class II materials consist of rounded particles and are less stable than the angular materials of Class IA and IB, unless they are confined and compacted.

#### 4.8.4 CLASS III MATERIALS

These materials provide less support for a given density than Class I or Class II materials. High levels of compactive effort are required if moisture content is not controlled. These materials will provide reasonable support once proper compaction is achieved.

#### 4.8.5 CLASS IV-A MATERIALS

Class IV-A materials are not recommended as suitable embedment material and must be carefully evaluated by a geotechnical engineer before use. The moisture content of the materials must be near optimum to minimize compactive effort and achieve the required density. Properly placed and compacted, these soils can provide reasonable levels of pipe support. However, these materials may not be suitable under high fills, surface applied dynamic loads, or under heavy vibratory compactors and tampers. These materials should be avoided if water conditions in the trench may cause instability and result in uncontrolled water content.

### 4.9 FINAL BACKFILL

This portion of the backfill begins 6 inches above the pipe (or from the initial backfill) to finished grade elevation. In cases where paving, sidewalks or other similar structures are planned, compaction of the final backfill is critical to prevent settling. However, if no such structures are anticipated, compaction of the final backfill is not as critical since it does not contribute to the structural integrity of the pipe system. The final backfill above the initial backfill material has no effect, except for weight, on flexible pipe performance.



Unless otherwise specified, trenches under pavements, sidewalks or roads should be backfilled and compacted to 90-percent density, as determined by the American Association of Highway and Transportation Officials Method T99 for State Compaction and Density of Soils. Recommendation on the use and precaution for use of rolling, vibratory and hydro hammers is found in [Section 4.10.2](#).

Unless specified, other trenches may be backfilled without controlled compaction in the final backfill. Additional backfill material should be supplied, if needed, to completely backfill the trenches or to fill depressions caused by subsequent settlement.

The trench and final backfilling should be carefully inspected to detect and remove any objectionable material such as large stones, frozen clumps of soil, bricks, etc., which may have fallen into the trench and be punched through the initial backfill damaging the pipe.



**Figure 30**

#### 4.10 COMPACTION METHODS AND EQUIPMENT

Selection of proper compaction equipment depends on the desired density and type of material being compacted. Crushed stone, sands and gravels are more easily compacted when vibratory equipment is used to transfer compaction energy. Highly plastic materials such as Class III and IV materials require moisture control plus and a higher amount of compaction energy induced by kneading and impact forces. Jumping jacks and walk-behind vibratory rollers are suitable for most classes of backfill materials, provided moisture content is controlled.

Crushed stone is usually not compacted. However, care must be taken to ensure the material is properly placed in the pipe haunch zone. Typically, using a shovel to knife the material in the haunch area provides suitable backfill support. Additionally, studies have shown that wetting the crushed stone reduces the friction between the fractured faces and improves in place strength of the material.



**Figure 31**

#### 4.10.1 HAND COMPACTION IN HAUNCH AREA

It is the discretion of the contractor (or design engineer) to determine the best method to achieve required compaction in the haunch area.

Tamping bars have been successfully used to compact the backfill in the pipe haunch zone.

#### 4.10.2 MECHANICAL TAMPERS

Care should be taken to avoid contact between the pipe and compaction equipment. Compaction of the embedment material should generally be done in such a way so that the compaction equipment is not used directly above the pipe until sufficient backfill has been placed to ensure that the use of compaction equipment will not damage or deflect the pipe.

When hydro-hammers are used to achieve compaction, they should not be used within 4 feet of the top of the pipe and then, only if the embedment material density has been previously compacted to a minimum 85 percent Proctor density.

### 4.10.3 WATER-JETTING

The introduction of water under pressure to the embedment material is not to be used to compact the embedment material.

### 4.10.4 COMPACTION EQUIPMENT SELECTION

Table 8 illustrates a selection guide for compaction equipment.

PROPERTY	SOIL CLASSIFICATION <sup>(1)</sup>			
	CLASS I	CLASS II	CLASS III	CLASS IV
Minimum % Compaction	Dumped	85%	90%	95%
Effort Required	Low	Moderate	High	Very High
Equipment Type	Hand Knifing in Haunch, Vibratory, Impact	Vibratory, Impact	Impact	Impact
Moisture Control	None	None	Near optimum to minimize compaction effort	Near optimum to minimize compaction effort

**Table 8**

**Notes:**

1. Soil classes defined in Table 6.
2. See ASTM D2321 for a complete definition.

### 4.11 MIGRATION

In soils where ground water fluctuations occur, coarse or open-graded material placed adjacent to a finer material may be infiltrated by those fines. Such hydraulic gradients may arise during trench construction when water levels are being controlled by various pumping or well-pointing methods, or after construction when permeable under drain or embedment materials act as a “French” drain under high groundwater levels. Downward percolation of surface water may carry fine materials down into more coarse, open-graded bedding materials if the trench is not properly designed and constructed. The gradation and relative particle size of the embedment and adjacent materials must be compatible in order to minimize migration. As a general precaution, it is recommended that if significant groundwater flow is anticipated, avoid placing coarse, open-graded materials adjacent to finer materials, unless methods are employed to impede migration, such as the use of an appropriate stone filter or fabric along the boundary of incompatible materials.

#### 4.12 PARALLEL PIPE INSTALLATION

Storm sewer conduits and underground drainage systems can be installed in parallel pipe configurations provided that the haunch zones are compacted with the proper amount and type of embedment material. Class I, II, and III materials are suitable for foundation and embedment. Minimum spacing between parallel pipes shall meet the minimum criteria set forth in [Table 9](#).

PARALLEL PIPE INSTALLATION MINIMUM SPACING	
NOMINAL ID IN (MM)	MINIMUM SPACING IN (MM)
ID ≤ 24 (600)	12 (300)
ID > 24 (600)	ID/2

**Table 9**

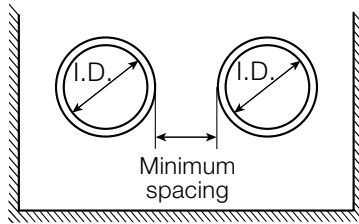

**Figure 32**

## 5.0 MINIMUM AND MAXIMUM BURIAL DEPTH RECOMMENDATIONS

### 5.1 BURIAL DEPTHS

Maximum and minimum burial depths are determined by the type of initial backfill material and compaction level (assuming a suitable foundation and bedding). Assuming the plans meet the initial backfill and compaction requirement of [Table 7](#) the construction plans should take precedence. Any discrepancies should be brought to the attention of the design engineer.

#### 5.1.1 MINIMUM COVER

In addition to the minimum cover height requirements, an extra foot of temporary cover is recommended where heavy-duty construction equipment may travel over the pipe during the construction phase of the project.

For H-25 traffic loads, a minimum cover of 12 inches, measured from the top of the pipe to the top of rigid pavement sections or the bottom of flexible pavement sections, is recommended for pipe diameters 48 inches and less.

For H-25 traffic loads, a minimum cover of 24 inches, measured from the top of the pipe to the top of rigid road surfaces or the bottom of flexible road surfaces, is recommended for 60-inch pipe. See [Table 10](#) for details.

Minimum covers may be reduced in areas with no or infrequent light traffic, provided flotation is not a concern and the design has been reviewed by an engineer.

MINIMUM COVER HEIGHTS	
NOMINAL ID IN (MM)	MINIMUM COVER FT (M)
ID ≤ 48" (1200)	1 (0.3)
ID = 60 (1500)	2 (0.6)

**Table 10**

### 5.1.2 MAXIMUM COVER

The information contained herein describes the maximum allowable cover height for Eagle Corr PE™ (Dual Wall). These recommendations address maximum burial depths for pipe meeting the requirements of AASHTO M252 Type S, M294 Type S, ASTM F2306 and ASTM F2648. This analysis is based on the design method developed by the Plastic Pipe Institute. The PPI design method is based on the actual pipe corrugation profile, which is conservative as evidenced by a long history of analytically predicted burial depths matching successful field installations.

The type and compaction level of backfill around the pipe significantly influence the maximum burial depth. These maximum cover height recommendations assume the native soil is of adequate strength and is suitable for installation.

Factors that influence maximum burial depth include, but are not limited to, backfill installed around the pipe and compaction level of the backfill. The maximum burial depth is typically controlled by the thrust load in the wall of the pipe. Governing the maximum burial depth with wall thrust yields very conservative burial depths. [Table 11](#) lists the maximum burial depths for a variety of standard installation conditions. Deeper burial depths may be obtained with specially designed trench or embankment conditions. Consult a qualified engineer for more details.

MAXIMUM COVER FOR EAGLE CORR PE™, FT								
DIAMETER IN (MM)	CLASS I		CLASS II			CLASS III		
	COMPACTED	DUMPED	95%	90%	85%	95%	90%	85%
4 (100)	60	20	40	28	20	28	21	19
6 (150)	63	22	43	30	22	31	23	21
8 (200)	61	20	41	28	20	29	21	19
10 (250)	61	20	40	28	20	28	21	19
12 (300)	55	17	35	24	17	25	18	16
15 (375)	55	17	35	24	17	24	18	15
18 (450)	53	16	34	23	16	23	17	14
24 (600)	54	16	34	23	16	24	17	14
30 (750)	51	14	32	21	14	22	15	13
36 (900)	49	13	31	20	13	21	14	12
42 (1050)	48	13	31	20	13	21	14	12
48 (1200)	48	13	30	20	13	20	14	11
60 (1500)	50	13	31	20	13	21	14	12

**Table 11**

**Notes:**

1. Backfill material classes are based on backfill material as described and defined in ASTM D2321.
2. All compaction levels are based on standard proctor density.
3. Compaction and backfill material should be uniform throughout the backfill zone.
4. Backfill material and compaction levels may be acceptable; however special designs must be approved by JM Eagle™ or an engineer.
5. Deeper burial depths may be obtained by consulting an engineer for special designs.

These cover heights do not take into consideration hydrostatic pressure. If hydrostatic pressure is anticipated the maximum burial depth may be reduced. Contact a qualified engineer for guidance.

**5.2 BURIAL DEPTH RECOMMENDATIONS**

The information contained herein describes the maximum allowable cover height for Eagle Corr PE™ (Dual Wall). These recommendations address maximum burial depths for pipe meeting the requirements of AASHTO M252 Type S, AASHTO M294 Type S, ASTM F2306 and ASTM F2648. This analysis is based on the design method developed by the Plastic Pipe Institute. The PPI design method is based on the actual pipe corrugation profile, which is conservative as evidenced by a long history of analytically predicted burial depths matching successful field installations.

### 5.3 MAXIMUM COVER HEIGHT ANALYSIS

The type and compaction of backfill around the pipe significantly influence the maximum burial depth. The influence of the backfill and compaction is illustrated in [Table 11](#), which was developed assuming the pipe is installed in accordance with ASTM D2321. These maximum cover height recommendations assume the native soil is of adequate strength and is suitable for installation. Additionally, the calculations assume no hydrostatic load and soil density of 120 pounds per cubic feet.



**Figure 33**

### 5.4 PIPE PROPERTIES



Key pipe profile properties that influence the performance of the soil/pipe structure interaction include the moment of inertia of the profile ( $I$ ), distance from the inside diameter to the neutral axis ( $c$ ), and the section area of a longitudinal profile section ( $A_s$ ). Pipe stiffness ( $PS$ ) is also important criteria. The minimum pipe stiffness, defined by AASHTO was used for this analysis. These key properties are summarized in [Table 12](#).

SECTION PROPERTY SUMMARY						
NOMINAL INSIDE DIAMETER (IN)	OUTSIDE DIAMETER (IN)	PIPE STIFFNESS, PS (PSI)	CROSS SECTIONAL AREA, $A_s$ (IN <sup>2</sup> /IN)	DISTANCE FROM INSIDE DIAMETER TO NEAURAL AXIS, $C$ (IN)	MOMENT OF INERTIA, $I$ (IN <sup>4</sup> /IN)	PITCH (IN)
4.0	4.7	50	0.076	0.14	0.0012	0.65
6.0	6.9	50	0.122	0.19	0.0037	0.78
8.0	9.1	50	0.146	0.28	0.0085	0.97
10.0	11.4	50	0.180	0.33	0.0171	1.29
12.0	14.3	50	0.183	0.47	0.0366	1.94
15.0	17.5	42	0.222	0.51	0.0549	2.59
18.0	20.8	40	0.244	0.58	0.0824	3.10
24.0	27.5	34	0.330	0.72	0.1593	3.10
30.0	34.6	28	0.370	0.95	0.3118	3.88
36.0	41.5	22	0.410	1.12	0.4986	5.17
42.0	47.4	20	0.448	1.18	0.5531	5.17
48.0	53.8	18	0.498	1.21	0.6551	5.17
60.0	66.7	14	0.660	1.44	1.2766	7.76

**Table 12**

**Note:** Section property data is considered conservative, however, properties may change based on actual production dimensions.

## 5.5 CONSTRUCTION AND PAVING EQUIPMENT LOADS

The design live load for the pipe is typically H-25 as defined by AASHTO. Some construction and paving equipment is not as heavy as an H-25 load. The vehicle load (surface pressure), backfill material and cover height all influence the allowable construction load. For the minimum backfill compaction and temporary construction loads, [Table 13](#) illustrates allowable minimum cover heights.

<b>MINIMUM TEMPORARY AND CONSTRUCTION COVER</b>		
<b>SURFACE PRESSURE INDUCED BY CONSTRUCTION VEHICLE (PSI)</b>	<b>TEMPORARY MINIMUM COVER FOR RESPECTIVE DIAMETERS</b>	
	<b>4" TO 48" DIAMETER PIPE<sup>(1)</sup></b>	<b>60" DIAMETER PIPE<sup>(1)</sup></b>
75	9-inches	12-inches
50	6-inches	9-inches
25	3-inches	6-inches

**Table 13**

Vehicles exceeding surface pressures must not be allowed over the installation.

Certain construction equipment exerts very high surface pressures or loads. For heavy construction equipment between 30 and 60 tons, it is recommended that an additional 1 to 2 feet of cover be placed over the pipe. Temporary fill may be placed over the pipe during construction and removed after the heavy construction equipment traffic is rerouted. For very heavy construction equipment (exceeding 60 tons) the minimum cover depends on the loading footprint of the equipment. Additional fill may or may not be required. Consult a qualified engineer for minimum cover heights necessary for very heavy equipment traffic.

## 5.6 SPECIAL CONDITIONS AND CONSIDERATIONS

### 5.6.1 FROZEN BACKFILL

Precautions should be taken to avoid installing pipe in frozen backfill. Installation in frozen backfill material can adversely affect the hydraulic and structural performance of the pipe. Concerns include, but not limited to the following:

1. Most soils have a tendency to adhere when frozen, becoming large lumps that can produce excessive impact on the pipe during the backfilling operation.
2. Frozen material that has expanded may produce excessive settlement in the trench backfill during the spring thaw.
3. Where the backfill material is extremely rocky, extra consideration should be given to the effects from frost because:
  - a. freezing occurs more rapidly.
  - b. rocks become lodged in frozen lumps of backfill.
4. These lumps can penetrate the soil cushion of the initial backfill over the pipe causing damage to the pipe.

### 5.6.2 VERTICAL INSTALLATION OR RISERS

Eagle Corr PE™ is installed vertically in special applications such as catch basins and clean-out risers. The soil structure interaction between pipe installed horizontally is different from pipe installed vertically. Therefore, vertical application appurtenances necessitate extra care during backfilling to provide proper support and to prevent damage to the piping. One of the most significant differences with vertical installations is the drag-down force exerted onto the structure as the backfill material consolidates. This drag-down force can be significant and cause the interior waterway wall to become wavy. Waviness generally does not have an adverse effect on the pipe, but should be avoided to the extent possible. [Figure 34](#) illustrates a typical vertical installation. Vertical installations of fittings like tees elbows, and wyes should be reviewed by a qualified engineer.

Limitations with vertical installations include the following:

1. Maximum burial height of a vertical structure shall be 8 feet or less, unless the system is specifically designed by a qualified engineer.
2. Structural backfill shall extend a minimum of 1 foot around the outside diameter of 4-inch to 24-inch diameter pipe. Structural backfill shall extend a minimum of 15 feet around the outside diameter of 30-inch and greater diameter pipe.
3. The concrete base must be designed sufficiently to overcome buoyant forces.
4. Grates, cast iron frames and other inlet structures must be designed by a qualified engineer and placed on a concrete collar around the inlet structure. The concrete collar must be designed to transfer its load to the ground around the pipe and must not be transferred to the pipe itself.
5. If the vertical structure is subjected to traffic loads, a concrete collar must be designed to transmit the load to the soil around the structure. The concrete collar and related appurtenances must be designed by a qualified engineer.

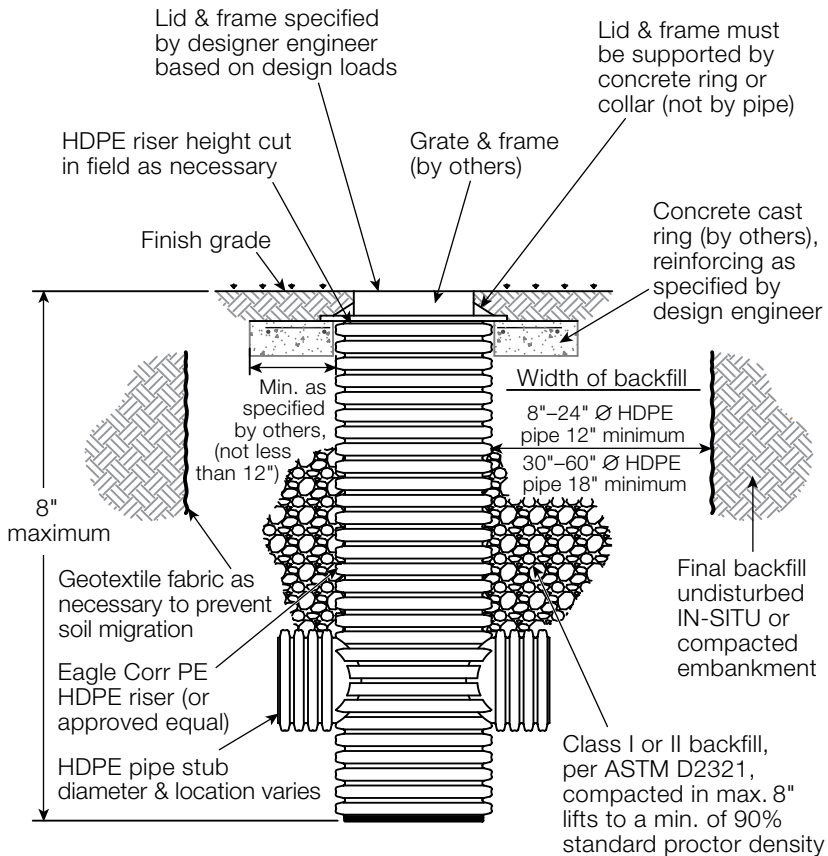

**Figure 34**

**Note:** The design engineer should assess the potential for flotation and take appropriate measures to prevent flotation in areas of high ground water.

**CAUTION:** Any vertical installation of pipe must be securely covered at the ground level. Open or unsecured ends create a risk of serious injury or even death to adults, children or animals who may enter or fall into vertically installed pipe. JM Eagle™ assumes no liability for losses resulting from failure to securely cover open ends or improper installation.

### 5.6.3 FLOTATION PREVENTION

Any type of pipe or structure, including concrete, will float. To prevent pipe flotation, a minimum amount of cover is required. The minimum cover recommended to prevent pipe flotation is shown in [Table 14](#).

<b>MINIMUM COVER TO PREVENT FLOTATION</b>	
<b>REQUIRED MINIMUM COVER</b>	
<b>NOMINAL DIAMETER (IN)</b>	<b>MINIMUM COVER<sup>(1)</sup> (IN)</b>
4	3
6	4
8	5
10	7
12	9
15	11
18	13
24	17
30	22
36	25
42	29
48	33
60	40

**Table 14**

**Notes:**

1. Water table is assumed to be at the ground surface as is usually the case with saturated soils.
2. Saturated soil density is 130 pcf with an internal angle of friction of  $O=0.37$ .
3. The pipe barrel is assumed to be empty.
4. The mean diameter of the pipe is used to calculate buoyancy.

5.6.4 GROUND WATER CONTROL

Ground water can prevent proper placement and compaction of backfill. Additionally, ground water in the trench can make obtaining proper moisture content for backfill impossible. If ground water is encountered, proper measures must be taken to maintain the ground water level below the trench bottom before pipe placement and after sufficient backfill is installed to prevent flotation. Appropriate ground water control methods include, but are not limited to, sump pumps, well points, deep wells perforated under drains and/or stone blankets.

### 5.6.5 BACKFILLING AND COMPACTING FOR PIPE ON SLOPES

Extra attention should be given to pipe installations on slopes to prevent the newly backfilled trench from becoming a “French drain.” Before the backfill completely consolidates, there is a tendency for ground and surface waters, to follow the direction of the looser soil. This flow of water may wash out soil from under or around the pipe, reducing or eliminating the support for the pipe. This can result in pipe failures. To avoid this potential problem with pipe installed on slopes, extra care should be taken to achieve greater compaction of the backfill. In this case, the compaction should be done in 4-inch layers and continued in this manner all the way up to the ground or surface line of the trench. To prevent water from undercutting the underside of the pipe, concrete collars, keyed into the trench sides and foundation, may be poured around the pipe.

## 6.0 PIPE TESTING AND REPAIR

Under normal conditions, a visual or video test provides sufficient inspection to identify proper pipe alignment and any deflection issues. Pipe joint testing is typically not necessary for drainage applications. If testing for deflection or pipe joints is required, the recommended methods of testing are addressed below.

### 6.1 DEFLECTION

Deflection is the reduction of the diameter of a flexible pipe due to an imposed

load as illustrated in [Figure 35](#).

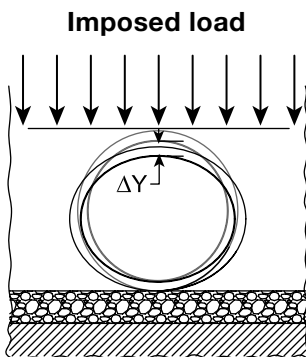

**Figure 35**

The amount of deflection that will occur after installation is a function of three parameters:

1. Pipe stiffness ( $f/\Delta y$ )
2. Soil stiffness (density) in the pipe zone.
3. Load imposed on the pipe.

Of the above three parameters, the most important influence on limiting deflection is soil stiffness (density) in the pipe zone, especially in the haunching area. See [Section 4.0](#), "Pipe Embedment" for the trench cross-section terminology.

Test data plotted for deflection as a function of load and soil density clearly show that deflection is controlled primarily by soil density in the pipe zone and by the soil modulus of the backfill material.

## 6.2 PIPE DEFLECTION TESTING

Deflection testing is generally not required when using proper construction



practices associated with initial backfill material selection, placement and compaction. However, if considered necessary, random deflection tests of pipe may be performed within 30 days of installation. Typical testing entails pulling a mandrel through 10 percent of the pipe installed, which provides a reasonable indication of installation quality. Since mandrel testing is a “go” or “no-go” test, any failures should be investigated. In many cases, a “no-go” mandrel test is a result of foreign material in the pipe, a slight joint offset or other similar condition. It is recommended to investigate the cause of the “no-go” test result before excavating to repair the system. [Table 15](#) indicates the base inside diameter and mandrel diameters settings for 7.5 percent deflection.

<b>RECOMMENDED MANDREL SETTINGS</b>		
<b>NOMINAL PIPE INSIDE DIAMETER (IN)</b>	<b>BASE INSIDE DIAMETER (IN.)</b>	<b>O.D. OF 7.5% DEFLECTION MANDREL (IN.)</b>
4	3.80	3.52
6	5.71	5.28
8	7.61	7.04
10	9.51	8.80
12	11.41	10.56
15	14.27	13.20
18	17.12	15.84
24	22.83	21.12
30	28.54	26.40
36	34.24	31.68
42	39.95	36.96
48	45.66	42.24
60	57.07	52.79

**Table 15**

Locations with excessive deflection should be repaired by re-bedding or replacement of the pipe. The maximum allowable deflection should be subtracted from the base inside diameters in determining the maximum diameter of the “go, no-go” test mandrel or ball. It must be emphasized that to insure accurate testing, the lines must be thoroughly cleaned.

### 6.3 PIPE JOINT LEAKAGE TESTING

Joint testing is typically not necessary for drainage applications. Larger diameters, which are predominately used in corrugated HDPE pipe, make pipe joint testing dangerous when testing with air. Therefore, if it is determined that watertight joint testing is required, the pipe must be tested in accordance with ASTM F2487: “Standard Practice for Infiltration and Exfiltration Acceptance Testing of Installed Corrugated High Density Polyethylene Pipelines.”

**WARNING:** Testing corrugated HDPE with air poses a hazard as a result of the stored energy associated with compressed air. Air testing may result in pipe failure and/or injury to property and/or persons.

## 6.4 REPAIR METHODS FOR PIPE

Repair methods largely depend on the performance expectations of the pipe joints and size of the damaged area of the pipe wall. Repair methods are generally divided into two categories (1) soil tight and (2) watertight, which are described below.

### 6.4.1 SOIL TIGHT REPAIR METHODS

#### Soil Tight Repair Option A – Split Band Coupler

This method can successfully repair 4 inches to 60 inches in diameter and involves wrapping a split band coupler around the pipe covering the damaged section. Limitations for this repair method include:

- Non-traffic applications (see Option B for traffic applications).
- Hole or damaged section of pipe less than or equal to 10 percent of the pipe diameter.

The following steps describe the repair process:

- Place split band coupler so that it is centered over the damaged area.

If one split ban coupler cannot completely cover the damaged area, use an alternative repair method.

- Wrap the coupler around the pipe while minimizing the disturbance of bedding and backfill.
- Tighten the nylon straps once the coupler is in place.
- Replace the bedding and initial backfill to ensure proper compaction and support for the pipe and coupler.

### Soil Tight Repair Option B – Concrete Collar

This method can successfully repair pipe 4 inches to 60 inches in diameter and involves pouring a concrete collar in place to encase the pipe and damaged section of pipe.

Limitations for this repair method include:

- Hole or damaged section of pipe less than or equal to 25 percent of the pipe diameter.
- In-situ foundation and bedding capable of handling the additional load associated with the weight of the concrete collar without excessive settling.

The following steps describe the repair process:

- Excavate area underneath the damaged section of pipe about 6 inches or to a firm foundation, whichever is greater.
- Wrap the pipe in the area of the damaged section with a non-woven geotextile such that the entire damaged area is covered.
- Brace the damaged section and geotextile as necessary.
- Pour concrete and encase the damaged section of pipe.
- Remove any bracing or struts.
- Carefully replace and compact initial and final backfill to provide support for the pipe.

**Note:** The concrete collar, as with any buried rigid structure, will attract load as the soil above it consolidates. Therefore, it is important to also compact the final backfill to minimize soil overburden loads associated with consolidation over the concrete collar.

### Soil Tight Repair Option C – Remove and Replace

This method involves removing and replacing a section of pipe and is used for pipe 4 inches to 60 inches in diameter. This method is typically reserved for extreme cases where the hole or damaged area exceeds 25 percent of the pipe diameter. Limitations for this repair method include:

- The pipe remaining in the ground should not have any structural damage.
- The pipe remaining in the ground should not exceed 7.5 percent deflection of the base diameter.

The following steps describe the repair process:

- Excavate an area along the length of the pipe sufficient to remove the damaged section of pipe plus exposing 2 feet of each end of the pipe remaining in the ground.
- Excavate a trench width sufficient to compact around the pipe to be replaced and to place necessary trench safety equipment.
- Cut out and remove the damaged section of pipe. Take care to cut the pipe between the corrugations.
- Prepare the bedding for pipe as described previously in this manual.
- Place an acceptable coupler under the existing pipe ends.
- Place the new section of pipe in the trench.
- Couple the ends of the pipe together.
- Carefully replace initial backfill to provide proper support.

**Note:** Acceptable coupling devices include split band couplers, concrete collars, Mar-Mac® couplers, Seal-Tite® or other coupling devices approved by the engineer.

#### 6.4.2 WATERTIGHT REPAIR METHODS

##### Watertight Repair Option A – PVC Repair Sleeves

This method involves removing and replacing a section of pipe and is used for pipe 4 inches to 24 inches in diameter. Limitations for this repair method include:

- 4-inch to 24-inch pipe may be repaired with this method.
- The pipe remaining in the ground should not have any structural damage.
- The pipe remaining in the ground should not exceed 5 percent deflection of the base diameter.

The following steps describe the repair process:

- Excavate an area along the length of the pipe sufficient to remove the damaged section of pipe plus exposing 3 feet of each end of the pipe remaining in the ground.
- Excavate a trench width sufficient to compact around the pipe to be replaced and to place necessary trench safety equipment.
- Cut out and remove the damaged section of pipe. Take care to cut the pipe between the corrugations.
- Prepare the bedding for pipe as described previously in this manual.
- Place PVC repair sleeves on each section of the pipe to remain in the ground.
- Place valley gaskets on each end of pipe to remain in the ground.
- Place valley gaskets on each end of the new section of pipe.
- Place the new section of pipe in the trench. (See [Figure 36](#) below.)
- Slide PVC repair sleeves so that they cover gaskets. Be sure and lubricate gaskets as required.
- Carefully replace initial backfill to provide proper support.

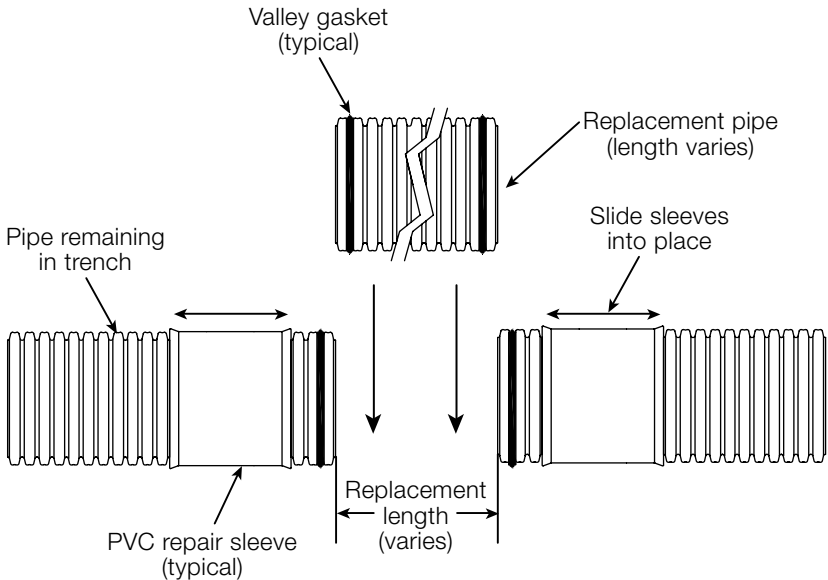

**Figure 36**

### Seal-Tite Couplers Option B – Seal-Tite Coupler

Seal-Tite is a coupling device with a gasket formed into the body of the device. Seal-Tite fits over the exterior of the full height corrugation and turns a plain-end piece of pipe into a belled pipe. Stainless steel bands tighten on top of the corrugations to form a watertight coupler. This field coupler is available for sizes from 24 inches to 48 inches.

#### **Watertight Repair Option C – Internal Sealing Rings**

Repairs to the interior of the pipe can be accomplished using internal sealing rings. Internal sealing rings are mechanical seals that are comprised of two or three stainless steel expansion rings and a rubber gasket. There are limitations on the width of the rubber gaskets; therefore, the size of the damaged area of pipe is somewhat limited. Contact a qualified engineer for more information.

#### **Watertight Repair Option D – Chemical Grouting**

This method is used to repair joints in place with a chemical grout. This method is commonly used to repair sanitary sewer joints and requires a contractor with specialized equipment. Chemical grout is forced from the inside of the pipe through a leaking pipe joint in a liquid form and sets up to form a flexible seal. The flexible seal forms a collar around the exterior of the joint and seals within the pipe joint.

Limitations for this repair method include:

- Sizes of chemical grout injection equipment (grout plugs).
- Access to the interior of the pipe.

#### **Watertight Repair Option E – Welding Pipe**

Pipe can be repaired by welding damaged areas. Typically the repair method is restricted to the interior of the pipe but welding the exterior of the pipe can also be performed. This repair work is performed by a contractor with specialized equipment.

**NOTICE TO ALL READERS OF THIS GUIDE:** Eagle Corr PE™ pipe installation may be hazardous to pipe, property, and/or persons if this guide and/or the recommendations of JM Eagle™ are not adhered to fully. JM Eagle™ has made every effort to expose all known dangers of misusing Eagle Corr PE™ pipe in this guide. However, JM Eagle™ cannot possibly know or anticipate all situations or outcomes. JM Eagle™ maintains the position that Eagle Corr PE™ pipe is a reliable and safe piping material. Thus, JM Eagle™ encourages all users of our products to exercise good judgment when installing our products and to consult JM Eagle™ for additional information when questions or concepts illustrated herein are not fully answered or understood. It is recommended that all users of our products (or people handling) attend training on pipe construction, installation and safety prior to working with our products to ensure safety, knowledge and understanding. Should you need further assistance, please contact JM Eagle™ Product Assurance at (800) 621-4404.











# JM Eagle

THE LEADER IN PIPE INNOVATION

THE HIGHEST LEVEL OF QUALITY

THE LARGEST BREADTH OF PRODUCT

THE WIDEST CAPACITY

EXPRESS DELIVERY

## PLANT LOCATIONS



DELIVERING GOOD WATER TO YOU

### GLOBAL HEADQUARTERS:

5200 West Century Blvd  
Los Angeles, CA 90045  
T: 800.621.4404  
F: 800.451.4170

[www.JMEagle.com](http://www.JMEagle.com)

### REGIONAL OFFICE:

Nine Peach Tree Hill Road  
Livingston, NJ 07039  
T: 973.535.1633  
F: 973.533.41785

PRINTED JANUARY 2017